

EXHIBITOR PROSPECTUS

36TH
ANNUAL

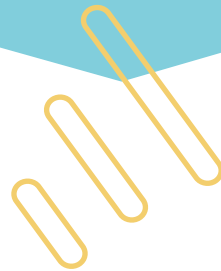

**ENVIRONMENTAL TRAINING
SYMPOSIUM & CONFERENCE**

**SAN DIEGO CONVENTION CENTER
SEPTEMBER 30 - OCTOBER 1, 2020**

Contact for more information:

Joelle Burila, Conference Coordinator

joelle.burila@ieaca.org

Claire Stuhr, Marketing and Events Assistant

claire.stuhr@ieaca.org

PHONE : (619) 522-9000

EMAIL: conference@ieaca.org

WEB : conference.ieaca.org



FAX: (619) 522-9005

ABOUT THE CONFERENCE 1985-2020

The 2020 Annual Environmental Training Symposium and Conference is presented by the Industrial Environmental Association and the California Manufacturers and Technology Association. For 35 years the Conference has excelled in providing a balance of valuable information that includes environmental compliance guidance, and regulatory and legislative updates.

ATTENDEES

The 500 attendees consist of environmental, health, and safety professionals, NGO representatives, environmental engineers, environmental consultants and attorneys, and government affairs representatives. These attendees represent manufacturing, biotech, and high tech companies, as well as the Department of Defense, and federal and state regulators.

SPEAKERS AND PANELISTS

Speakers and panelists include California legislators and regulators who are at the forefront of environmental policy at the State and Federal level. Additionally, you will find award-winning consultants, representatives from a variety of non-governmental organizations, and leading California businesses.



PAST SPEAKERS INCLUDE

Alexis Strauss, EPA Region 9

Amy Mmagu, California Chamber of Commerce

Barbara Lee, Director, DTSC

Bob Kard, Jon Adams, Rob Reider, San Diego APCD

Congressman Scott Peters

Councilmember Mark Kersey, Ruth Kolb, City of San Diego

Diane Takvorian, Environmental Health Coalition

Karl Palmer, OEHHA

Sande Pence, San Diego County, Dept. of Environmental Health

Matt O'Malley, San Diego Coastkeeper

Matt Rodriguez, Cal/EPA

RADM Yancy Lindsey, Capt. John Adcenetz, Department of Defense

Richard Corey, Ron Roberts, CARB

Scott Smithline, CalRecycle

Steve Moore, David Gibson, CA State Water Resources Control Board

Sue Gornick, CCEEB

Supervisor Greg Cox, District 1, San Diego County Board of Supervisors



PROGRAM TOPICS

Topics vary from year to year depending on current legislation and regulations. However, each year there are returning favorites. The conference program is shared online as it is developed.

Visit conference.ieaca.org

PREVIOUS TOPICS

Air Permitting Workshop
Air Regulatory Updates
Carbon Management
Changing Energy Landscape
Climate Action Plans
Climate Emission Reduction Initiatives
Compliance Updates
CUPA Updates
Drought Management
Emergency Planning & Response
Environmental Justice
Environmental Planning / CEQA / NEPA
Green Chemistry
Hazardous Materials
Inspector's Update
New Legislation
Prop 65
Recycling and Waste Reduction
Regulatory Proceedings
Risk Management Principles
Stormwater
Sustainable Business Practices
QISP Training Workshop



CONFERENCE AT A GLANCE

DAY 1

- **7:00AM** | Registration and Continental Breakfast
- **7:45AM** | Morning Plenary Session
- **9:15AM** | Educational Sessions
- **10:30AM** | Coffee Break
- **11:00AM** | Educational Sessions
- **12:30PM** | Environmental Excellence Awards Luncheon
- **1:45PM** | Poster Presentations
- **2:15PM** | Educational Sessions
- **3:30PM** | Snack Break
- **4:00PM** | Educational Sessions
- **5:15PM** | Cocktail Reception

DAY 2

- **7:00AM** | Registration and Continental Breakfast
- **7:45AM** | Morning Plenary Session
- **9:15AM** | Educational Sessions and Workshops
- **10:30AM** | Coffee Break
- **11:00AM** | Educational Sessions and Workshops
- **12:15PM** | Lunch
- **1:15PM** | Educational Sessions
- **2:30PM** | Snack Break
- **3:00PM** | Educational Sessions
- **4:15PM** | End of Conference

Schedule is subject to change

PHONE : (619) 522-9000

EMAIL: conference@ieaca.org

WEB : conference.ieaca.org

FAX: (619) 522-9005

GENERAL INFORMATION

REGISTRATION INFORMATION

Registration for attendees is available online at conference.ieaca.org. Please email conference@ieaca.org for manual registration.

BADGE PICK-UP

All attendees, including exhibitors, can pick up their badge in the registration area at the San Diego Convention Center beginning on **Wednesday, September 30**.

PAYMENT

All payments for conference registration, workshops, exhibit booths, and sponsorships can be paid with a credit card or check.

Credit Card: Credit Card payments have additional service and processing fees.

Checks: Please make checks payable to "Industrial Environmental Association."

Remit to:
Attn: Joelle Burila
Industrial Environmental Association
1330 Orange Ave, Suite 100
Coronado, CA 92118

WHAT'S NEW FOR 2020

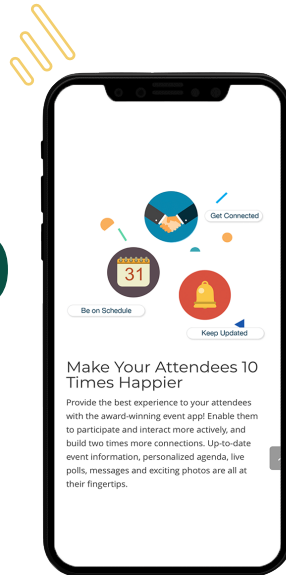

GOVERNMENT PERSONNEL

Employees of any State, County, Regional, Municipal, or Federal agency qualify for the Government registration rate.

WORKSHOPS

Workshops are included in conference fees. If you're interested in attending only the workshops, you may register for the "Workshop Only" separately on Eventbrite. Please check for program updates on our website.

SPONSORS AND EXHIBITORS

Sponsors and Exhibitors are eligible for complimentary conference pass(es), according to the respective guidelines in the prospectus. Please refer to the sponsorships and exhibitor options in this packet. You may register for a sponsorship or exhibit booth by completing the sponsor/exhibitor registration form.

STUDENT SCHOLARSHIPS

Each year we do our best to offer scholarships for undergraduate and graduate students to attend conference. Although we cannot guarantee scholarships every year, we encourage students to apply. Please visit our website to apply.

Conference Mobile App

Mobile Brochure

- Personalized Agenda, Multi-Track Support
- Interactive Maps
- Document Sharing
- Preview Speaker Bios

Attendee Engagement and Networking

- Attendee Profiles
- Instant Messaging and Group Chat
- Business Card Scanning and Exchanging
- Surveys and Live Polling
- Photo Sharing

GENERAL INFORMATION (CONT'D)

CONFERENCE LOCATION

SAN DIEGO CONVENTION CENTER
111 W HARBOR DRIVE
SAN DIEGO, CA 92101

Banquet Hall 6B

Exhibit Hall 6A

Breakout Rooms 3, 4, 5A, 5B

The Convention Center is a 10 minute car ride from the San Diego International Airport.



CONVENTION CENTER PARKING

Parking is included in conference registration fees. You'll receive a parking pass via email two weeks prior to conference. Parking passes are only valid on September 30 - October 1, 2020.

No in and out privileges. No overnight parking permitted.

NOTE: YOUR PARKING PASS MUST BE PRINTED. YOU WILL NOT BE PERMITTED ENTRANCE WITHOUT A PRINTED PASS.

PHONE : (619) 522-9000

EMAIL: conference@ieaca.org

WEB : conference.ieaca.org

FAX: (619) 522-9005



HOTEL ACCOMMODATIONS

Discounted hotel accommodations are available at Hotel Indigo San Diego Gaslamp Quarter and Marriot San Diego Gaslamp Quarter. The hotels are within 10-15 minutes walking distance from the San Diego Convention Center.

Hotel rates are only guaranteed for reservations made by Sunday, August 30.

HOTEL INDIGO SAN DIEGO GASLAMP QUARTER

509 9TH AVE
SAN DIEGO, CA 92101

From \$169 per night + hotel fees

Parking

Valet overnight parking fee: \$49 USD daily

Valet parking fee: \$20 USD daily

Hotel does not offer self-parking

How to make a reservation:

Call (866) 384-3015

Identify yourself as part of the IEA Conference Room Block

To make reservations online, visit conference.ieaca.org

SAN DIEGO MARRIOTT GASLAMP QUARTER

660 K ST
SAN DIEGO, CA 92101

From \$199 per night + hotel fees

Parking

Valet overnight parking fee: \$48 USD daily

How to make a reservation:

Call (877) 622-3056

Identify yourself as part of the IEA Conference Room Block

To make reservations online, visit conference.ieaca.org

TRANSPORTATION OPTIONS

The hotels do not provide a shuttle to/from the San Diego Intl Airport.

However, many ground transportation options are available including Taxi, Lyft, Uber, or SuperShuttle.



EXHIBITOR OPPORTUNITIES

2020
CONFERENCE

EXHIBIT HALL

The exhibit hall is the hub for attendees to mingle between sessions. It serves as the location for continental breakfast, all coffee and snack breaks, and the popular reception on day one.

HOURS

Wednesday, September 30, 7:00am - 6:30pm
Thursday, October 1, 7:00am - 1:00pm

ON-SITE BOOTH PERSONNEL

Exhibitors are allowed two on-site representatives to tend their booth. There must be a person present at their booth at all times. Names of representatives must be provided by September 1.

Any additional personnel must be registered separately at an additional cost.

WHAT'S NEW FOR EXHIBITORS? Conference Mobile App for Exhibitors

Key Benefits

- Exhibitor Profiles
- Exhibitor Directory
- Social Media Integration
- Built-in QR Code Scanner
- Private In-App Messaging

LEVELS

PLATINUM EXHIBITOR

GOLD EXHIBITOR

SILVER EXHIBITOR

		AMOUNT	\$5,000	\$4,300	\$2,700
EXHIBITOR BENEFITS	BOOTH SPACE, INCLUDING 1 DRAPED 6' TABLE AND 2 CHAIRS	✓	✓	✓	✓
	# OF COMPLIMENTARY CONFERENCE PASSES	2	2	1	
	TWO SEATS AT THE ENVIRONMENTAL EXCELLENCE AWARDS LUNCHEON	✓	✓	✓	
	SPECIAL INTRODUCTION AT THE PLENARY AND OPPORTUNITY TO PROMOTE YOUR COMPANY	✓			
	LOGO PRINTED ON POSTERS	✓	✓		
	COMPANY NAME LISTED IN PROGRAM AS AN EXHIBITOR	✓	✓	✓	
	LIST OF CONFERENCE ATTENDEES EMAILED PRIOR TO CONFERENCE	✓	✓	✓	
	CONFERENCE PARKING PASS	✓	✓	✓	
	LOGO ON IEA'S WEBSITE	✓	✓	✓	
	500 WATT OUTLET	✓	✓	✓	

EXHIBITOR OPPORTUNITIES (CONT'D)

EXHIBITOR DETAILS AND GUIDELINES

EXHIBIT HALL LOCATION

Location of the exhibit hall is in room 6A of the Convention Center.

EXHIBIT BOOTH SELECTION

Once payment is complete, reservations will be assigned in date receipt order.

EXHIBIT INSTALLATION

Tuesday, September 29
5:00pm - 7:00pm

EXHIBIT DISMANTLE

Thursday, October 1
1:00pm - 3:00pm

CONVENTION CENTER PARKING

You must pay for parking on installation day. Otherwise, parking is included in your exhibitor package. You will receive your parking pass via email two weeks prior to conference. Please note the pass must be printed and is only valid on September 30 - October 1, 2020. Please refer to Page 5.

DELIVERIES

The IEA conference does not have a service contractor. The convention center will not accept delivery of show materials or freight without an official service contractor. Please coordinate deliveries with your hotel or union labor.

Please direct any inquiries to:

JOELLE BURILA
CONFERENCE COORDINATOR
(619) 522-9000
JOELLE.BURILA@IEACA.ORG

PHONE : (619) 522-9000

EMAIL: conference@ieaca.org

WEB : conference.ieaca.org

FAX: (619) 522-9005

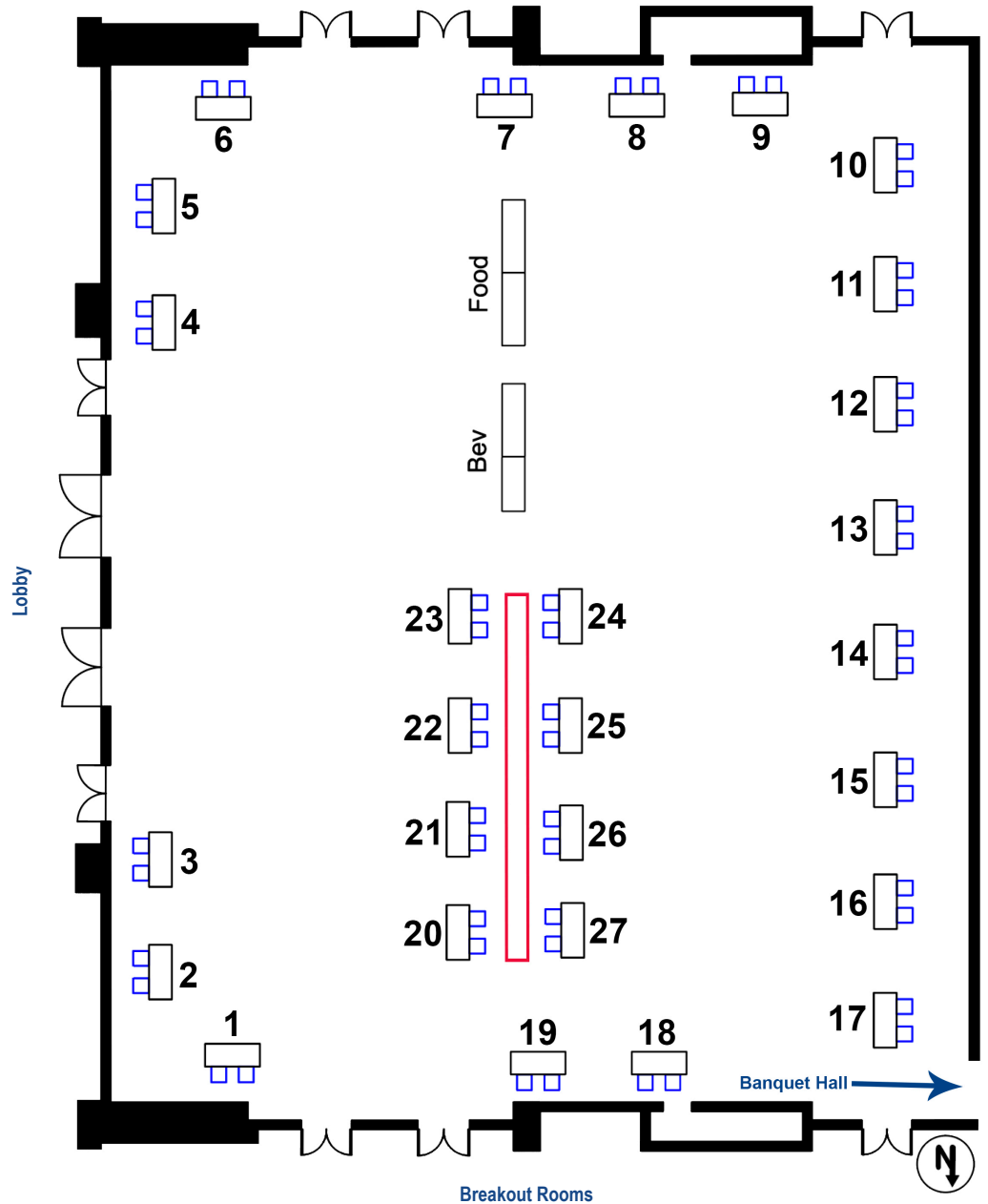

Sponsor / Exhibitor Registration Form

36th Annual Environmental Training Symposium and Conference
September 30 - October 1, 2020 | San Diego Convention Center



To confirm your sponsorship or exhibit booth, complete this form and send to conference@ieaca.org.

Date:

Company Information: Please print or type the following information, as you would like it to appear in conference materials.

Company:

Address:

City, State, Zip Code:

Phone:

Fax:

E-mail:

Website/URL:

Primary Contact: This person will be the primary point of communication and will be sent all information related to your participation.

Contact Name & Title:

Contact Phone:

Contact E-mail:

CHECK HERE IF SPONSOR

CHECK HERE IF EXHIBITOR

Sponsorship Information: Choose your desired sponsorship level.

- | | |
|--|---|
| <input type="checkbox"/> Platinum Sponsor \$10,000 | <input type="checkbox"/> Sustainability Track Sponsor \$2,300 |
| <input type="checkbox"/> Gold Sponsor \$7,500 | <input type="checkbox"/> Water Track Sponsor \$2,500 |
| <input type="checkbox"/> Bronze Sponsor \$5,000 | <input type="checkbox"/> Coffee Break Sponsor (2) \$2,000 |
| <input type="checkbox"/> Conference Mobile App Sponsor \$4,000 | <input type="checkbox"/> Snack Break Sponsor (2) \$2,000 |
| <input type="checkbox"/> Environmental Excellence Luncheon Sponsor \$4,000 | <input type="checkbox"/> CA Legislator of the Year Award Sponsor \$1,750 |
| <input type="checkbox"/> Keynote Speaker Sponsor (2) \$3,500 | <input type="checkbox"/> CA Regulator of the Year Award Sponsor \$1,750 |
| <input type="checkbox"/> Cocktail Reception Sponsor \$3,000 | <input type="checkbox"/> Local Legislator of the Year Award Sponsor \$1,500 |
| <input type="checkbox"/> Environmental Excellence Awards Sponsor \$3,000 | <input type="checkbox"/> Associate of the Year Award \$1,500 |
| <input type="checkbox"/> Lanyard Sponsor \$2,750 | <input type="checkbox"/> Workshop Sponsor \$1,500 |
| <input type="checkbox"/> Water Bottle Sponsor \$2,200 | <input type="checkbox"/> Educational Scholarship Sponsor \$1,750 |
| <input type="checkbox"/> Air Track Sponsor \$2,500 | <input type="checkbox"/> Individual Scholarship Sponsor \$400 |
| <input type="checkbox"/> HazMat Track Sponsor \$2,500 | <input type="checkbox"/> Single Session Sponsor \$300 |
| <input type="checkbox"/> Health & Safety Track Sponsor \$2,000 | |

Questions? Contact Joelle Burila at conference@ieaca.org or call (619) 522-9000

Sponsor / Exhibitor Registration Form

36th Annual Environmental Training Symposium and Conference
September 30 - October 1, 2020 | San Diego Convention Center



Exhibitor Information: Choose your desired exhibitor level. Exhibit space is not confirmed until payment is received.

Platinum (3) | \$5,000

Gold | \$4,300

Silver | \$2,700

Booth Number: 1st Choice

2nd Choice

3rd Choice

4th Choice

Staff Names: Please refer to our prospectus to view your number of complimentary passes associated with the sponsor and/or exhibitor package.

Complimentary Pass(es)

Name	Job Title	E-mail	Phone
1.			
2.			

Should any of your attendee names change, please notify conference@ieaca.org at least 2 weeks prior to conference.

EXHIBITOR ONLY – ONSITE BOOTH PERSONNEL

Exhibitor Representatives

Name	Job Title	E-mail	Phone
1.			
2.			

Should any of your exhibitor representative names change, please notify conference@ieaca.org at least 2 weeks prior to conference.

Company Description: Please include a brief description about the nature of your business and the products/services you provide.

Company Logo: All Sponsors and Exhibitors must email their company logo. Please send your logo in the highest resolution possible. Acceptable formats are .ai, .eps, .jpeg, .png. Email your company logo to conference@ieaca.org.

Payment Information: All payments for sponsors and exhibitors can be paid with a check or credit card. We will send you an invoice once we receive this completed form. Please select your method of payment:

CHECK

CREDIT CARD

Make checks payable to *Industrial Environmental Association*. Remit payment to:

There is an additional 4% service and processing fee associated with all credit card payments.

Attn: Joelle Burila
Industrial Environmental Association
1330 Orange Ave, Suite 100
Coronado, CA 92118

Questions? Contact Joelle Burila at conference@ieaca.org or call (619) 522-9000